

MATLAB EXPO 2018

Co-diseño Hardware-Software
para Control de Motores

Luis López

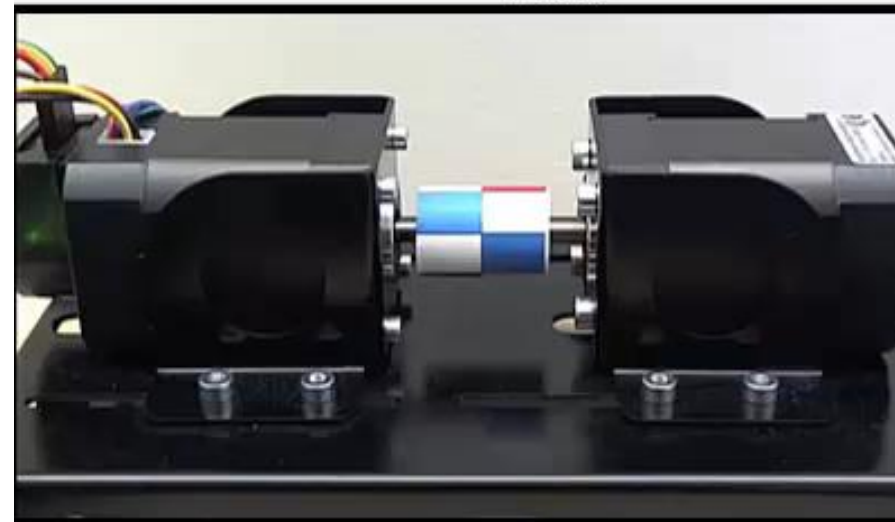

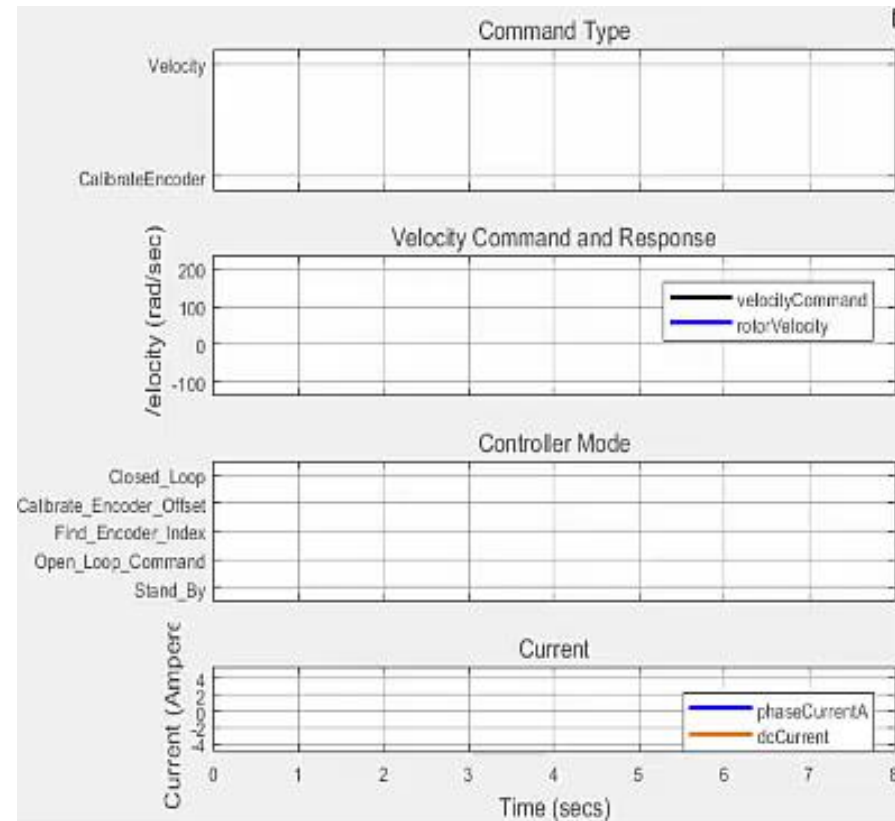

Takeaways

Model-Based Design for SoC FPGAs

- Enables early validation of specifications using simulation
- Improves design team collaboration and designer productivity.
- Reduces hardware testing time by 5x

Punch Powertrain develops complex SoC-based motor control

- Powertrains for hybrid and electric vehicles
- Need to increase power density and efficiency at a reduced cost
 - Integrate motor and power electronics in the transmission
- New switched reluctance motor
 - Fast: 2x the speed of their previous motor
 - Target to a Xilinx® Zynq® SoC 7045 device
 - Complex: 4 different control strategies
- No experience designing FPGAs!

[Link to video of presentation](#)

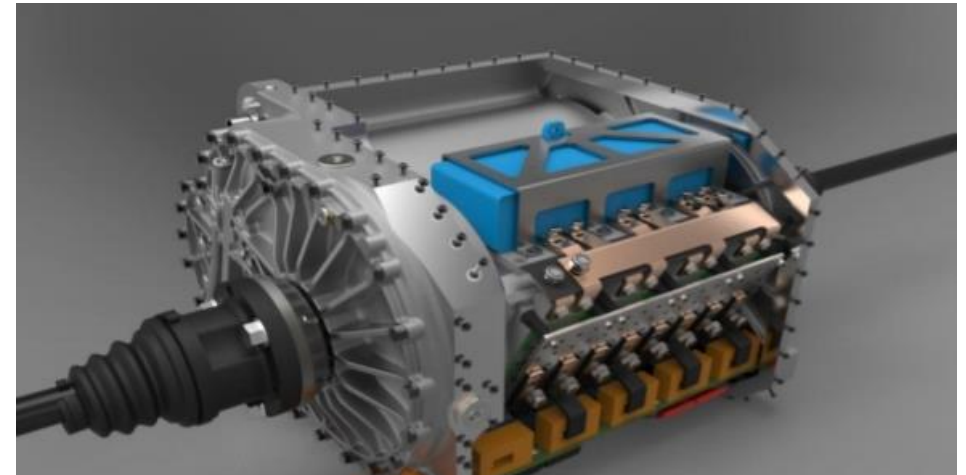

- ✓ Designed integrated E-drive: Motor, power electronics and software
- ✓ 4 different control strategies implemented
- ✓ Completed in 1.5 years with 2FTE's
- ✓ Models reusable for production
- ✓ Smooth integration and validation due to development process – thorough validation before electronics are produced and put in the testbench

Key trend: Increasing demands from motor drives

- Advanced algorithms require faster computing performance.
 - Field-Oriented Control
 - Sensorless motor control
 - Vibration detection and suppression
 - Multi-axis control



What's an SoC?

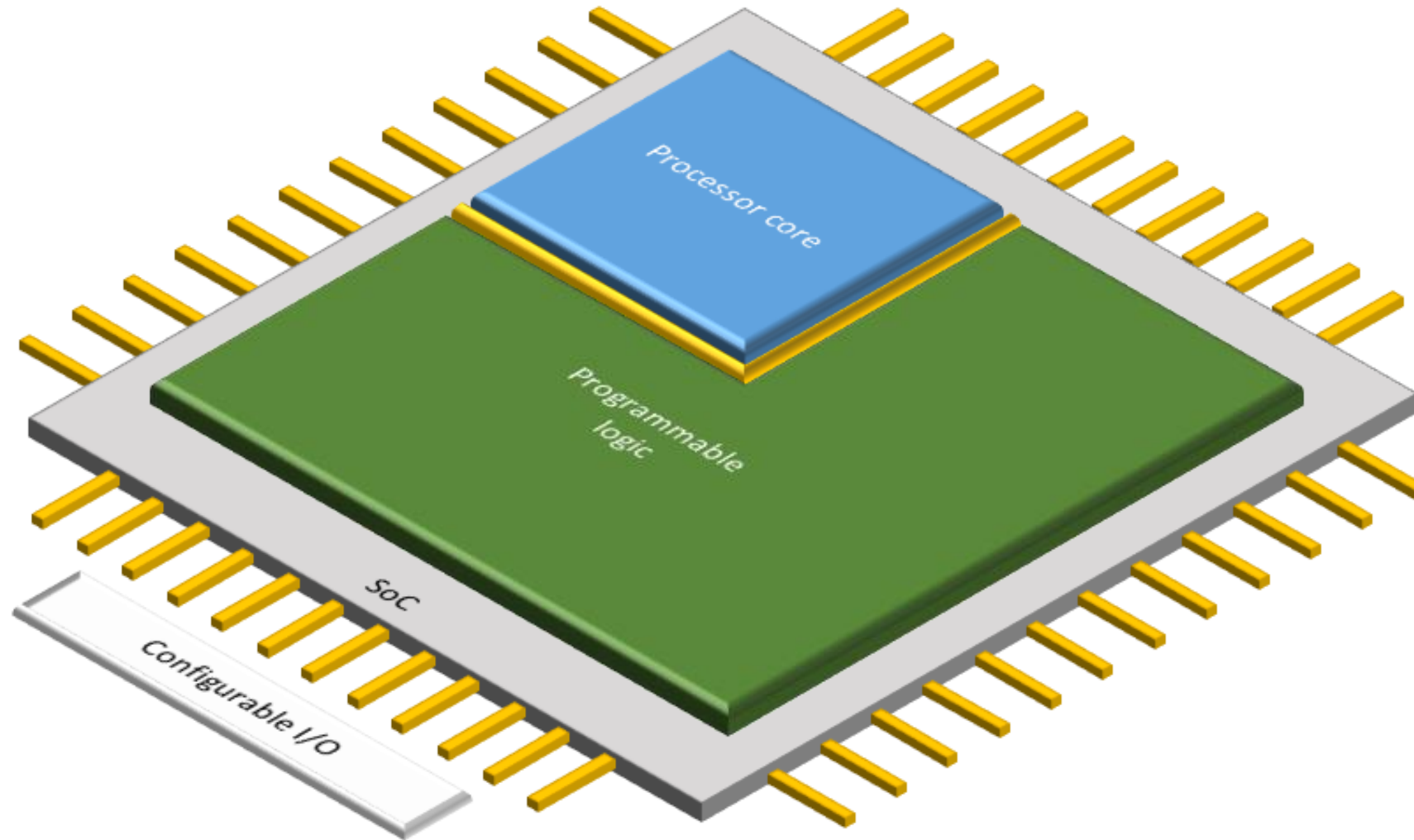

Key Trend: SoCs are now used in 36% of new FPGA projects

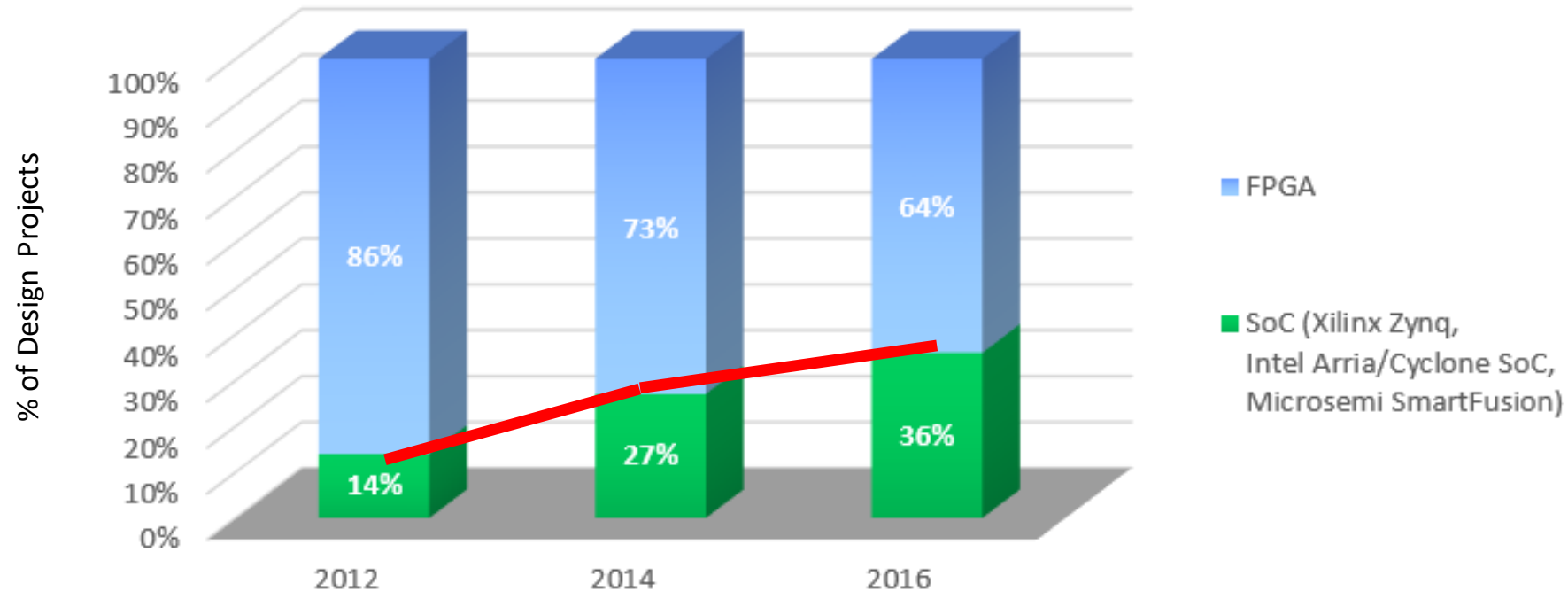

Challenges in using SoCs for Motor and Power Control

- Integration of software and hardware partitions of algorithm on SoC drives need for collaboration
- Validation of design specifications with limits on access to motors in labs.
- How to make design decisions that cut across system components?

Why use Model-Based Design to develop motor control applications on SoCs?

- Enables early validation of specifications using simulation months before hardware is available.
- Improves design team collaboration and designer productivity by using a shared design environment.
- Reduces hardware testing time by 5x by shifting design from lab to the desktop

ZedBoard

Zynq SoC
(XC7Z020)

Load motor

Mechanical
coupler

FMC module:
control board +
low-voltage board

Motor under test
(with encoder)

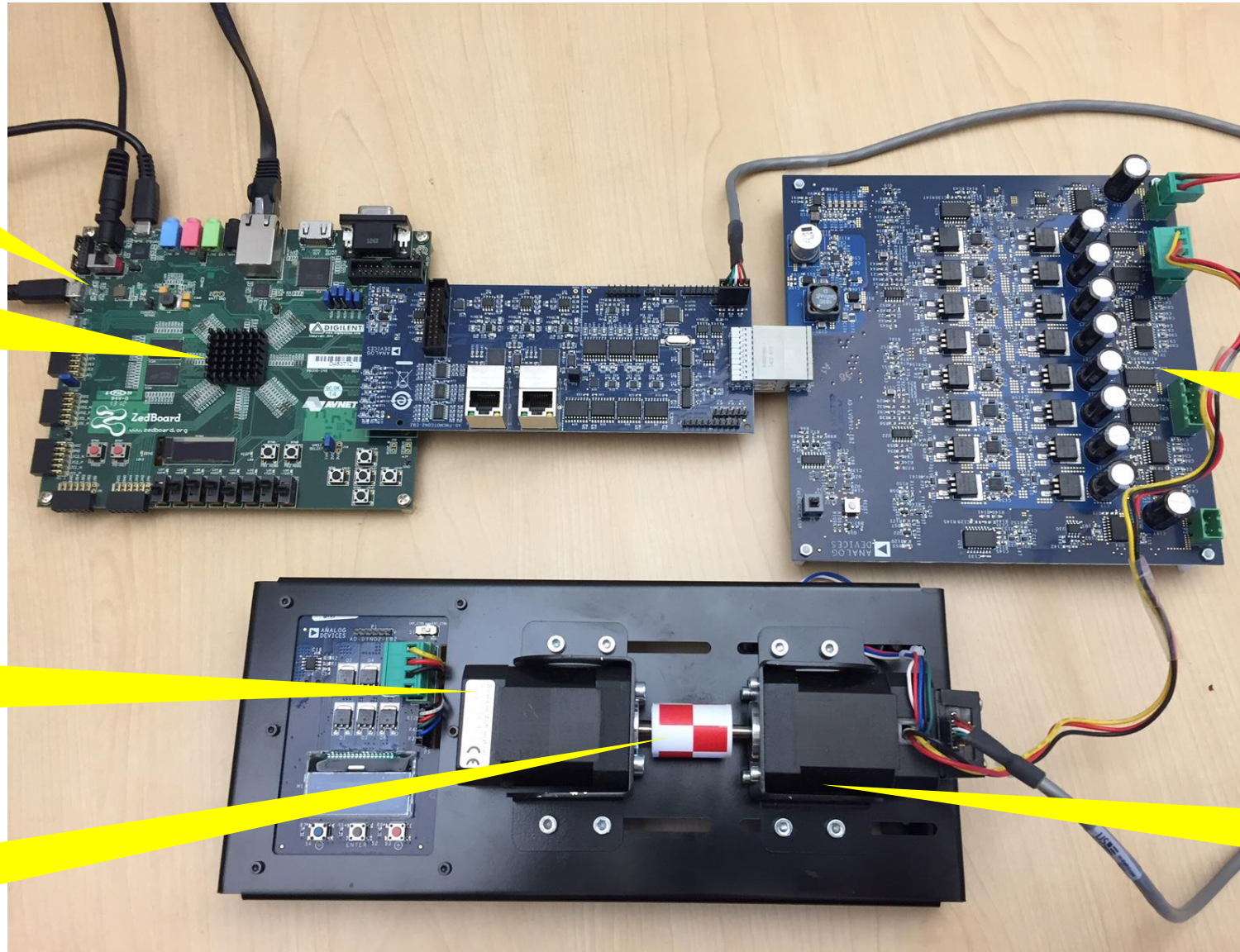

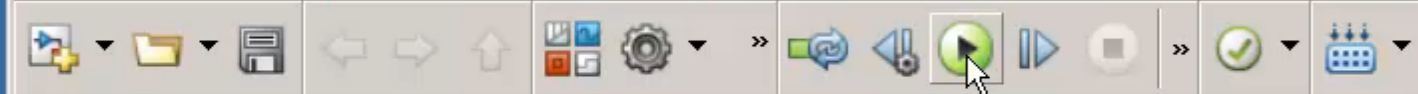

focZynqTestBench

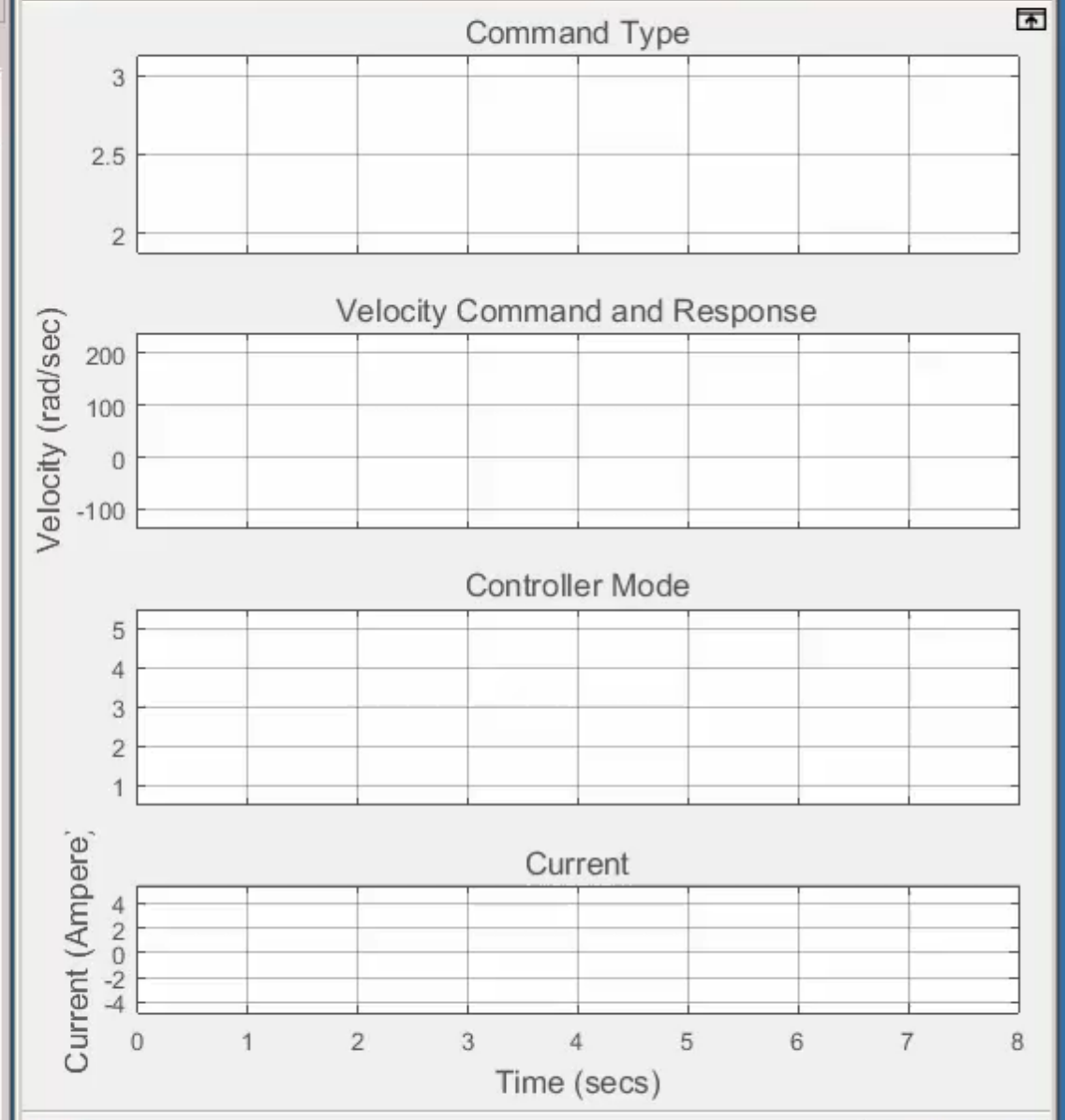
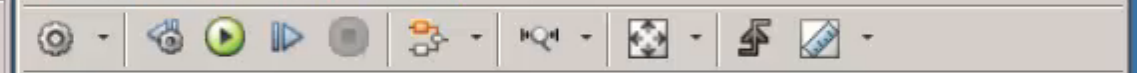
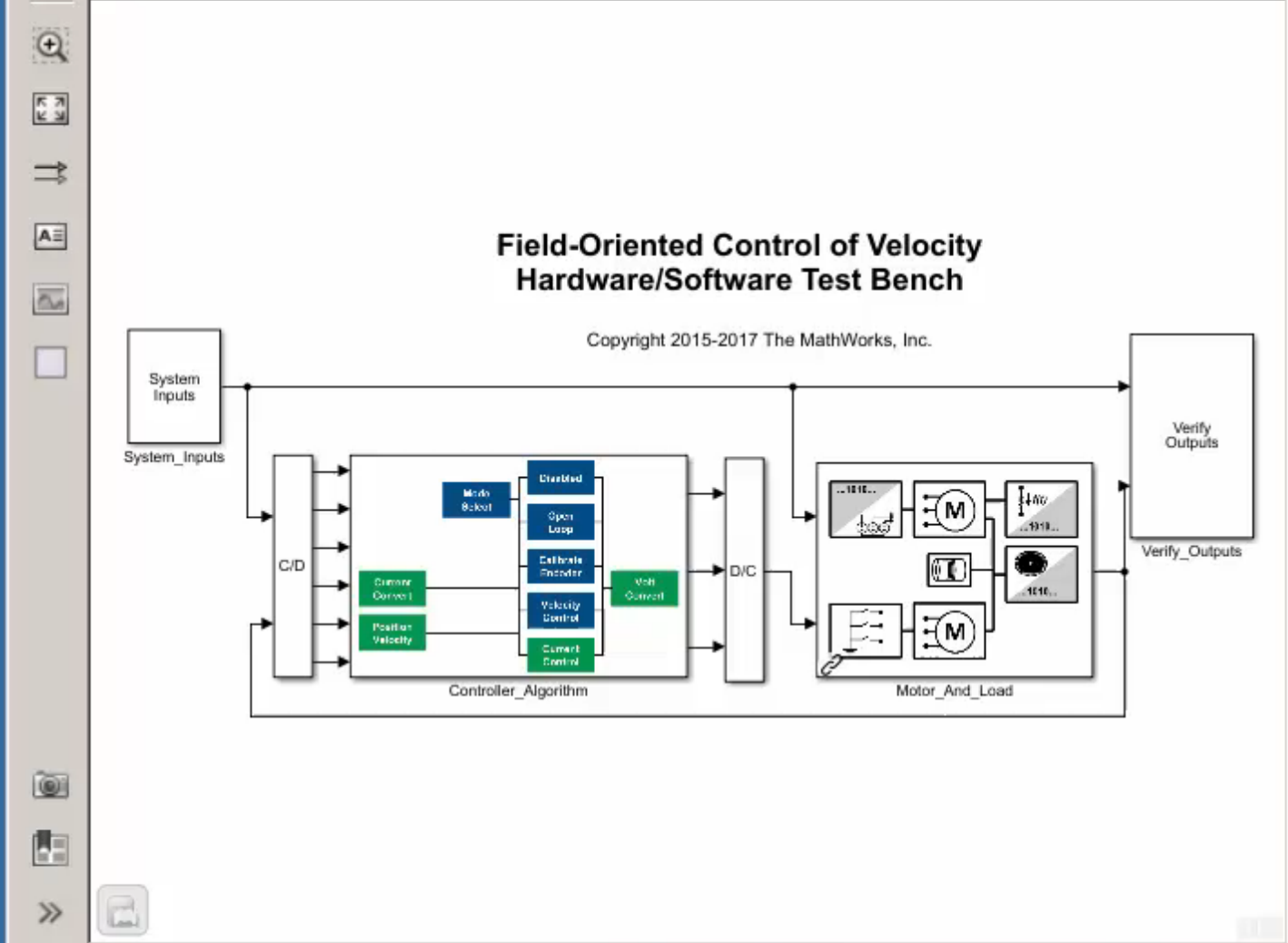

Conceptual workflow targeting SoCs

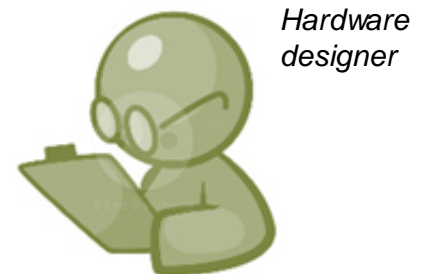
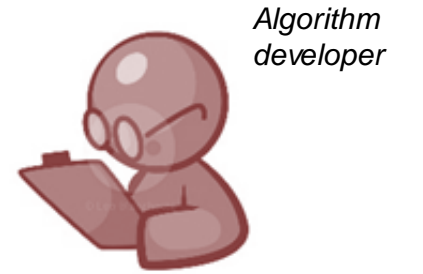
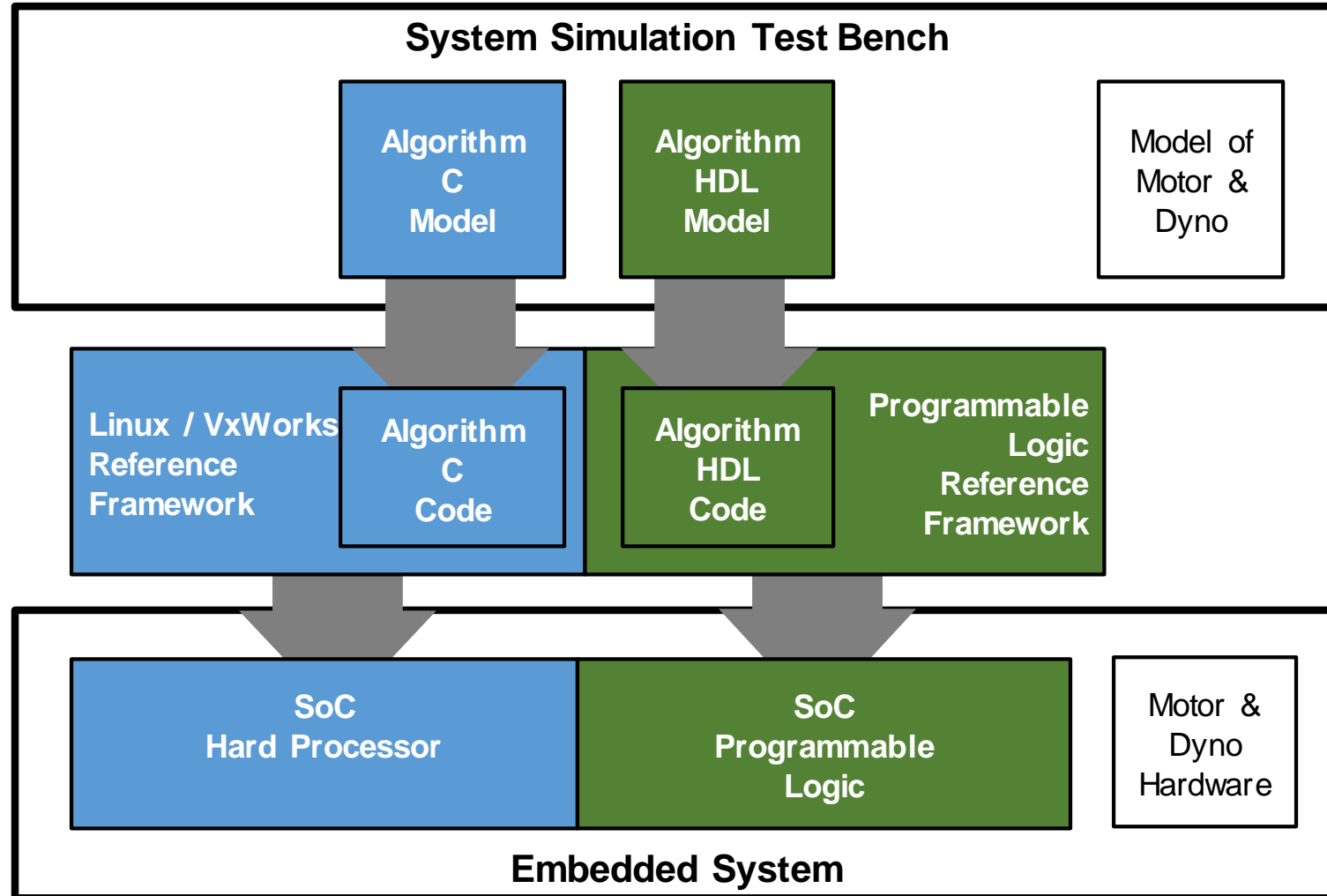
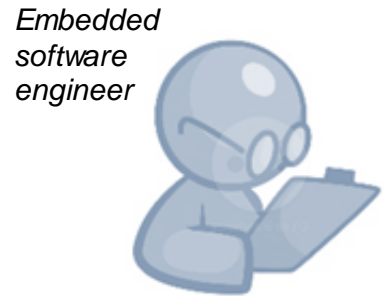

Hardware/software partitioning

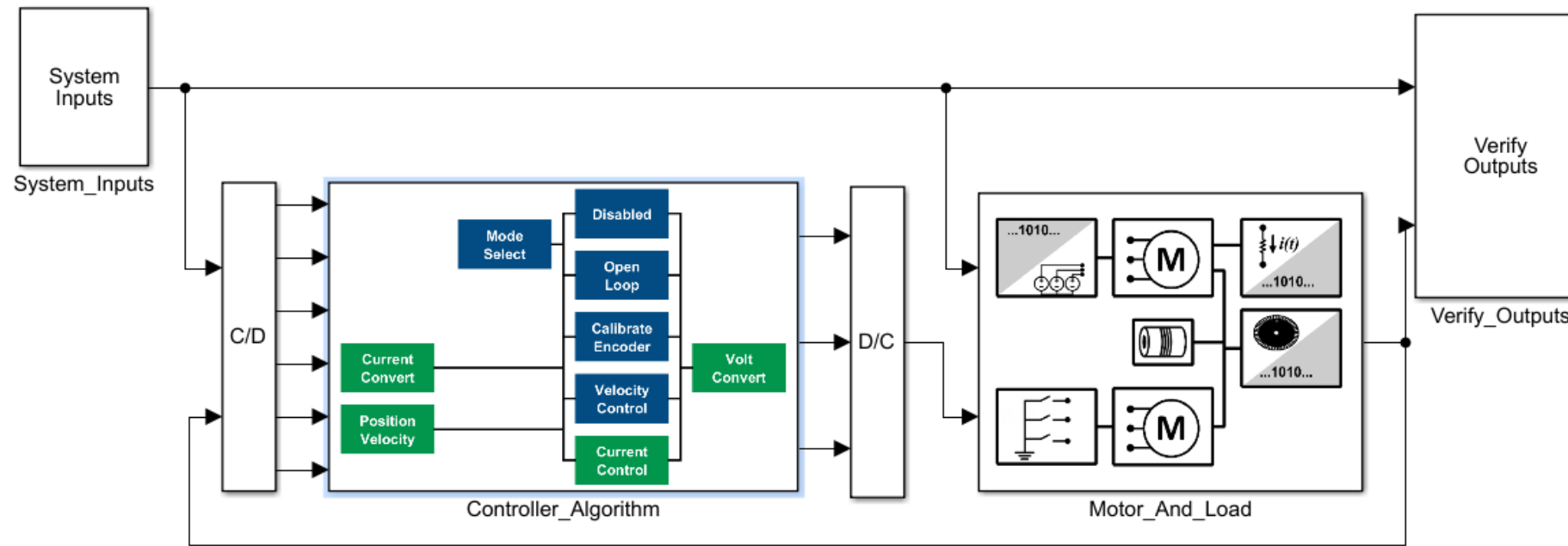

Target to Programmable Logic

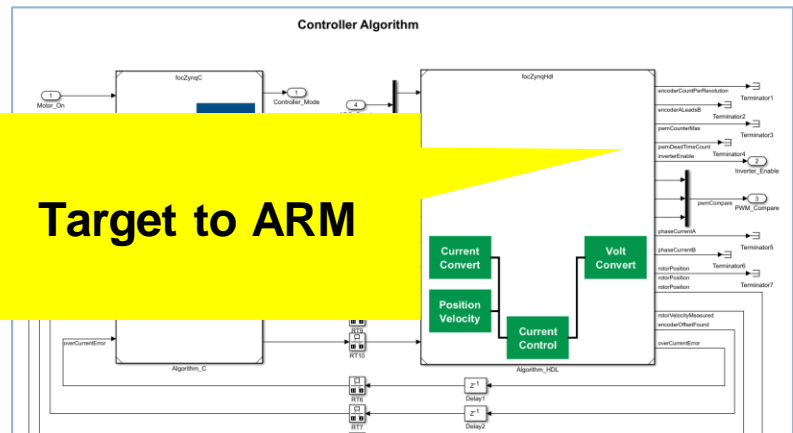

Code Generation

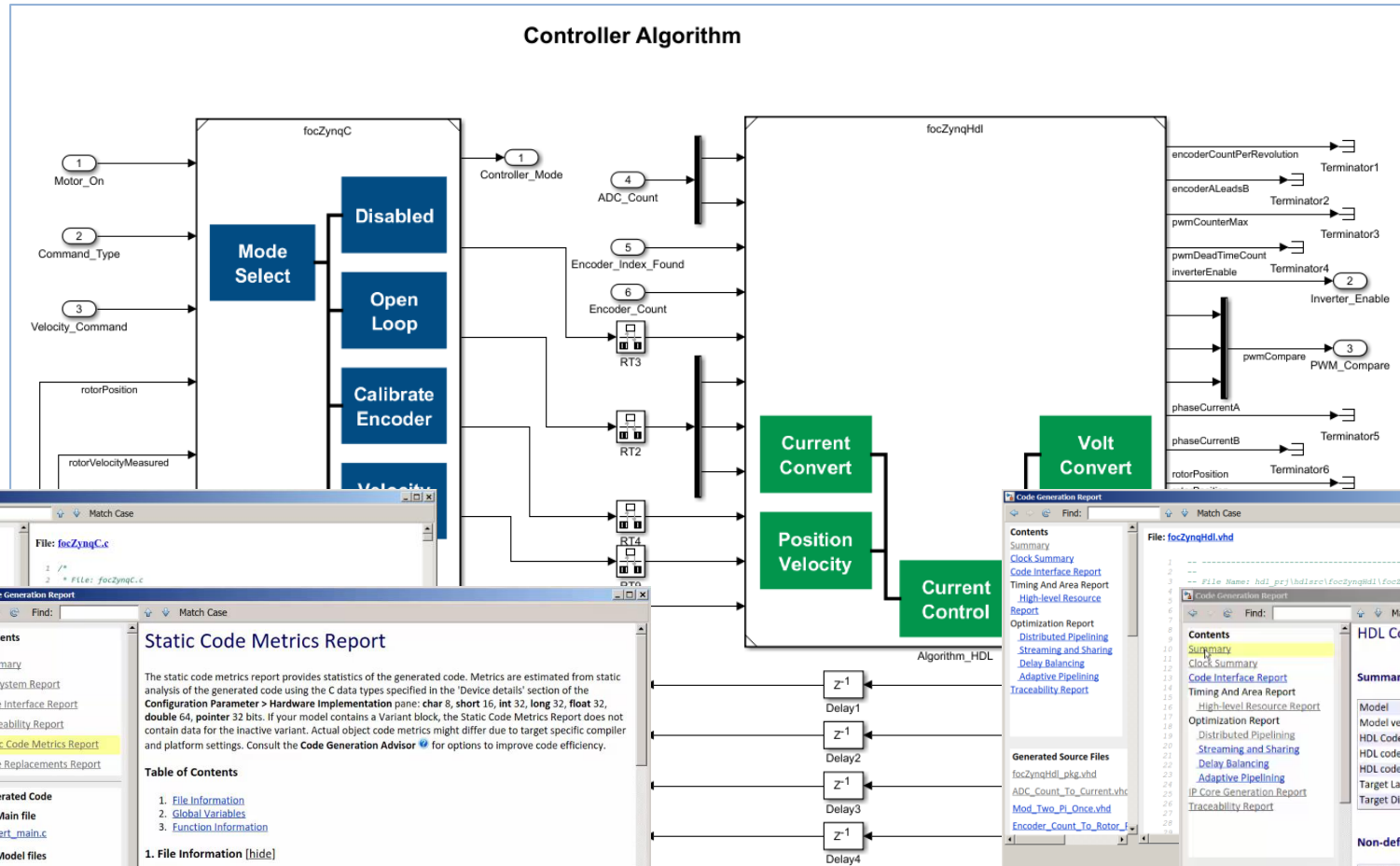

Static Code Metrics Report

The static code metrics report provides statistics of the generated code. Metrics are estimated from static analysis of the generated code using the C data types specified in the 'Device details' section of the Configuration Parameter > Hardware Implementation pane: char 8, short 16, int 32, long 32, float 32, double 64, pointer 32 bits. If your model contains a Variant block, the Static Code Metrics Report does not contain data for the inactive variant. Actual object code metrics might differ due to target specific compiler and platform settings. Consult the Code Generation Advisor for options to improve code efficiency.

Table of Contents

- File Information
- Global Variables
- Function Information

1. File Information [hide]

(-) Summary (excludes ert_main.c)

Number of .c files : 5
 Number of .h files : 9
 Lines of code : 901
 Lines : 2,116

File Name	Lines of Code	Lines	Generated On
fociZynqC.c	417	883	04/19/2017 9:48 PM
fociZynqC.h	130	347	04/19/2017 9:48 PM
fociZynqC_data.c	66	318	04/19/2017 9:48 PM

HDL Code Generation Report Summary for fociZynqHdl

Summary

Model	fociZynqHdl
Model version	1.368
HDL code version	3.10
HDL code generated on	2017-04-21 14:19:09
HDL code generated for	fociZynqHdl
Target Language	VHDL
Target Directory	hdl_prj\hdlsrc

Non-default model properties

ClockRatePipelining	off
EnablePrefix	oversampledClockEnable
HDLSubsystem	fociZynqHdl
ModulePrefix	fociZynqHdl_ip_src_
OptimizationReport	on
Oversampling	2000
ReferenceDesign	Motor Control Reference Design
ResetType	Synchronous
ResourceReport	on
ScalarizePorts	on
SynthesisTool	Xilinx Vivado
SynthesisToolChainFamily	7nm

Field-Oriented Control of Velocity Zynq ARM Deployment for AD-FMCMOTCON2

Copyright 2015-2016 The MathWorks, Inc.

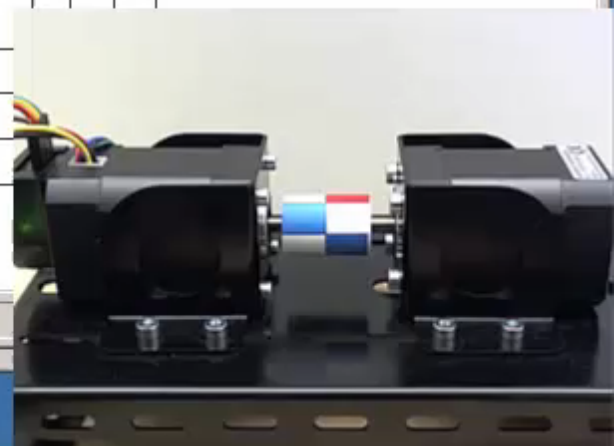
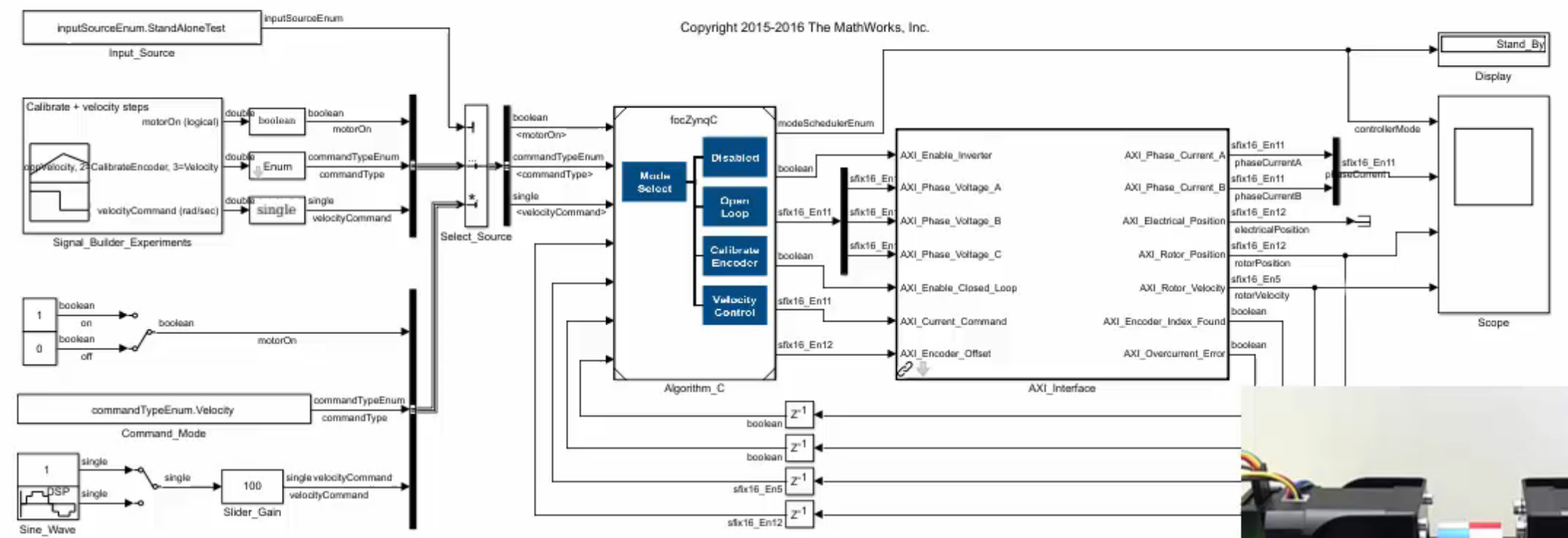

3T Develops Robot Emergency Braking System with Model-Based Design

Challenge

Design and implement a robot emergency braking system with minimal hardware testing

Solution

Model-Based Design with Simulink and HDL Coder to model, verify, and implement the controller

Results

- Cleanroom time reduced from weeks to days
- Late requirement changes rapidly implemented
- Complex bug resolved in one day



A SCARA robot.

“With Simulink and HDL Coder we eliminated programming errors and automated delay balancing, pipelining, and other tedious and error-prone tasks. As a result, we were able to easily and quickly implement change requests from our customer and reduce time-to-market.”

Ronald van der Meer

3T

Why use Model-Based Design to develop motor control applications on SoCs?

Challenges:

- Integration of software and hardware partitions of algorithm on SoC drives need for collaboration
- Validation of design specifications with limits on access to motors in labs.
- How to make design decisions that cut across system?

Model-Based Design

- ✓ Enables early validation of specifications using simulation months before hardware is available.
- ✓ Improves design team collaboration and designer productivity by using a shared design environment.
- ✓ Reduces hardware testing time by 5x by shifting design from lab to the desktop

Learn More

- Videos

- [HDL Coder: Native Floating Point](#)

- Webinars

- [Prototyping SoC-based Motor Controllers on Intel SoCs with MATLAB and Simulink](#)
- [How to Build Custom Motor Controllers for Zynq SoCs with MATLAB and Simulink](#)

- Articles

- [How Modeling Helps Embedded Engineers Develop Applications for SoCs \(MATLAB Digest\)](#)
- [MATLAB and Simulink Aid HW-SW Codesign of Zynq SoCs \(Xcell Software Journal\)](#)

- Tutorials:

- [Define and Register Custom Board and Reference Design for SoC Workflow](#)
- [Field-Oriented Control of a Permanent Magnet Synchronous Machine on SoCs](#)



MathWorks
58.426 volgers
16 d

MathWorks is honored to receive the Embedded World Award 2017 in the Tools Category for HDL Coder. <http://owl.li/nBzd309XYxW>

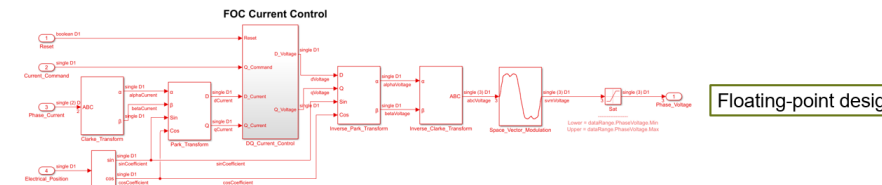
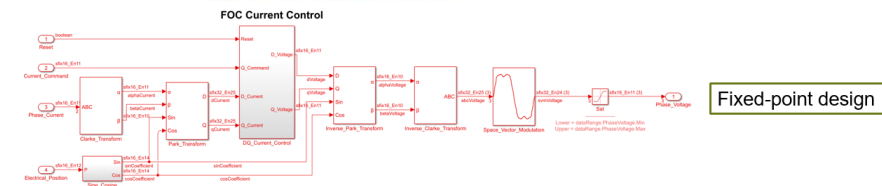

288 interessant • 6 commentaren